

Remedial Sealant Application

by Karen L. Warseck

Building owners and managers have many incentives to maintain the integrity of building sealing and to prevent air and water penetration. Elimination of exterior leaks prevents costly interior water damage. Air leaks waste energy and increase the cost of heating and cooling. Water entry into masonry may result in freeze-thaw damage.

In most cases, it is possible to re-caulk and eliminate or compensate for problems that have caused past sealant failures. But, careful inspection to locate and determine causes of leakage, selection of the appropriate sealant, and proper surface preparation and application techniques are *essential* to avoid repeat failures and to assure the longevity of the remedial work.

Finding and Analyzing the Leaks

The first step in a proper remedial project is to locate the source of the leak. Look for failed caulking and open areas around window and door frames, joinery in metal curtainwalls, expansion joints, copings, parapet flashings, vent collars, air conditioning units, ductwork, and electrical conduit. Roofing materials and structural cracking and failures should also be thoroughly investigated. In glazing

assemblies, look for brittle and cracked glazing compounds, or caulking tapes or sealants that have pumped out of their original position. Check also for openings or adhesion failures in cap, toe, or heel beads.

If exact water leakage points are not obvious, the easiest way to find them is with a simple water hose test. Starting outside at the bottom of the structure, spray water on the suspected leakage areas and observe the building interior. Repeat this process, floor by floor, up to and including the roof and flashings. It is important that this testing be done from the bottom to the top rather than vice versa. Water entering from upper floors can run down structural members or conduits to lower floors, obscuring the actual leakage point and giving the appearance of a leak in the wrong area. Be sure to allow enough time for water to get to the low points on the building interior and seep through porous materials before proceeding to the next higher floor.

Air leakage points may be more difficult to detect. In cold weather, the interior entry areas are easily identified, but the origin of the outside air may not be so obvious. Careful visual

examination may spot exterior air leakage points but, in many window units and curtain walls, air seals are hidden. If detail drawings of the building structure are not available, careful study by a qualified architect or engineer can pinpoint suspect areas. Disassembly of window or curtain wall facades may be necessary to confirm the leakage point and make necessary repairs.

Once the leakage areas are found, the architect can determine the proper method of remedial correction. Visual inspection of the failed caulking usually reveals the cause of the failure. The old sealant may have become brittle and dry due to weathering, cohesively cracked due to excessive joint movement for that particular sealant, or may show loss of adhesion to the joint surfaces due to poor original preparation, weathering, movement, surface incompatibility, or poor sealant performance. In glazing assemblies, many sealants lose adhesion to glass due to degradation (caused by ultraviolet radiation) of the sealant at the bondline. Failure can also be caused by a combination of these factors.

(continued)

If areas of air or water penetration were previously unsealed, a judgement must be made as to the consequence of sealing these areas. Many curtain wall systems are designed to allow water entry. The water is then channeled back to the exterior of the building through interior gutters or weeps. Sealing these gutters or weeps would cause water to back up and run to the interior, causing serious damage to the structure and its contents. Glazing channels where insulating glass (IG) units are installed require that a weep system be used. Sealing weep holes in these assemblies can cause failures and voiding of any IG warranties. Standing water can degrade the edge seals on the insulating glass units. Freezing water, expanding as it freezes, can cause glass breakage. Many buildings are designed to allow air to enter to equalize pressures or to vent moisture vapor. Review of drawings by a qualified architect or engineer can determine which areas must remain unsealed and what action should be taken instead.

Selecting the Sealant

Selecting the sealant which will give the best performance in a given area is complicated by the wide variety of caulking and sealants on the market, all of which are designed for a specific function and application.

As a general rule, the butyls, acrylics and paintable silicone caulks are used in interior or exterior applications where little movement is expected. These sealants normally have air-to-good weather resistance and adhesion. They may be used on a variety of substrates and will accept and hold paint.

In exterior applications where moderate to extreme movement, weather

exposure, ozone and ultra-violet light (sunlight) are factors, sealants such as the polyurethanes, polysulfides and silicone sealants may be considered.

In some structures, the movement may be cumulative and impossible to predict. In such cases, sealants with high movement capability should be used to provide a maximum safety factor. The polysulfide and polyurethane sealants are recommended for movements from ± 12.5 to $\pm 25\%$. Due to their resistance to weathering and flexibility and resilience at temperature extremes, silicone sealants are recommended for movement as high as $\pm 50\%$. It is important that the movement capability of the sealant be adequate to accommodate the expected movement for a given joint width. For example, if the expected movement in a butt joint is known to be $\pm 1/16$ " and the joint width is only $1/8$ ", only a $\pm 50\%$ movement capability sealant will perform in that joint.

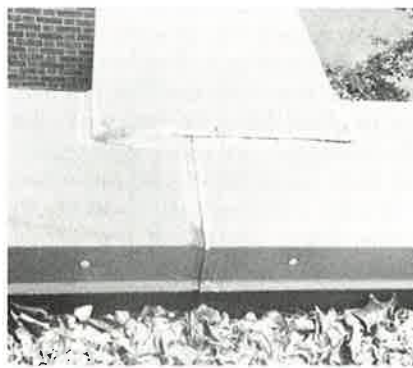

excessive joint movement caused sealant failure in this metal coping

The proper choice of sealant also depends upon the job site conditions and weather conditions at the time of application. If mixing of two-part sealant on the job site will cause problems due to untrained personnel, logistics,



failed sealant in aluminum curtain wall

added costs, temperature extremes, etc., a one-part sealant is a logical choice. If sealing has to be accomplished at low or extremely high temperatures, the sealant chosen must be recommended by the manufacturer for application under these conditions. At low temperatures, most sealants become very viscous, hard to gun, and may not wet the surfaces properly for best adhesion. Conversely, the same sealants may exhibit a tendency to sag and flow in the joint if application or substrate temperatures are too high.

In addition to application problems, low temperatures retard the cure of many sealants. Some organic sealants which cure through in days at 70°F and 50% relative humidity may take several weeks to cure through at temperatures below 40°F. As a result, surface cracking, deformation or splitting through the sealant may occur due to movement during cure. Sealing at temperature extremes also affects the width of butt joints to be sealed. A sealant that is acceptable for a joint installed at 70°F may not be acceptable for use in the same joint at expected temperature extremes. If a

technical notes

sealant is installed when the joint is at its minimum or maximum width, the total movement from that period of time is in one direction, subjecting the sealant to extreme stress either in compression or tension. In lap shear joints, the relative stress is always in tension but in different directions depending on temperature at time of installation.

Removal of Old Caulking

In remedial applications, all sealant manufacturers recommend all old sealant be removed, especially if the new sealant is of a different type. Removal of old sealant can be very difficult and usually requires cutting to the bond line, then using solvent or mechanical means to completely remove all traces of the sealant film from the joint surface.

If, for some reason, the old sealant cannot be removed, sometimes a technique referred to as the "Band Aid" technique may be used. This involves placement of a polyethylene bond breaker tape over the old sealant and application of the new sealant over and beyond the edges of the tape forming a new joint. Before the technique is used, however, be sure there are no compatibility problems between the old and new sealant.

Application of the New Sealant

For the remedial sealant application to be successful, the surface preparation must be appropriate for the substrate and the sealant to be applied. The substrate must be sound and free from dirt, grease, old sealant, or any other material that would inhibit the adhesion of the new sealant. If a primer is required, it should be applied only to a clean, dry, sound surface. The recommendations of the sealant

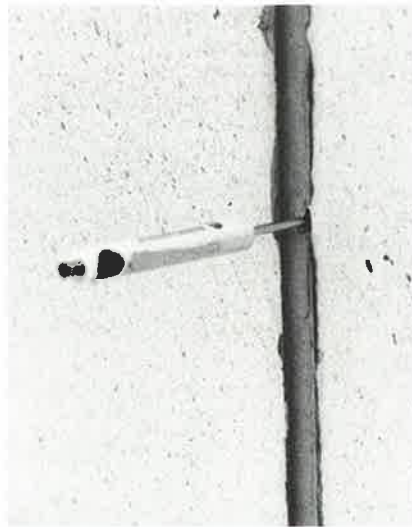

probe shows lack of sealant adhesion to substrate



adhesive failure

manufacturer should be strictly followed to be sure the sealant will not fail adhesively due to improper surface preparation. A field test for adhesion should be performed before proceeding with the work to determine if proper adhesion of the new sealant will be obtained. Adequate time for sealant cure should be allowed before testing for adhesion. Time required for optimum adhesion varies with particular sealants. Each type of substrate should be tested.

When the test sample has been approved, the sealant should be applied in accordance with the manufacturer's recommendations. Backer rod or bond breaker tape should be applied as required. Care should be taken so that the backer rod is not inserted too far into the joint. The optimum depth is one half the joint width. Once the sealant is applied, before it skins over, it should be tooled to force it against the backer rod and to form a concave surface. The sealant should be applied without edge gaps and allowed to cure undisturbed.

The importance of tooling the joint cannot be overstressed. If the sealant is not tooled to a concave surface or forced against the backer rod, adhesive failure is more likely to occur. The thickened center of the sealant bead will allow greater stresses to develop along the bond line when the joint is in tension, making failure more likely. By making the sealant surface slightly concave, the joint is freer to stretch, creating less stress at the bond and easing the chance of adhesive failure.

Conclusion

A property owner or manager can benefit greatly from resealing his or her building. With careful analysis of the causes of leakage, proper sealant selection for the intended use, and proper preparation and application techniques, the building can be maintained air or water tight for many years to come.

The information in this article came in part from "Remedial Caulking" published by General Electric Company's Silicone Products Division, Waterford, NY.

Sealant Adhesion Tests

by Jerry Klosowski
Dow Corning Corporation

As a check for adhesion of sealant to substrate, a hand pull test may be run at the jobsite after the sealant has fully cured. (Usually within 14-21 days.) To begin the procedure on a vertical surface, make a knife cut horizontally from one side of the joint to the other. Make two vertical cuts approximately two inches long at the sides of the joint, meeting the horizontal cut at the top of the vertical cuts. Follow the appropriate steps for high or low modulus sealants.

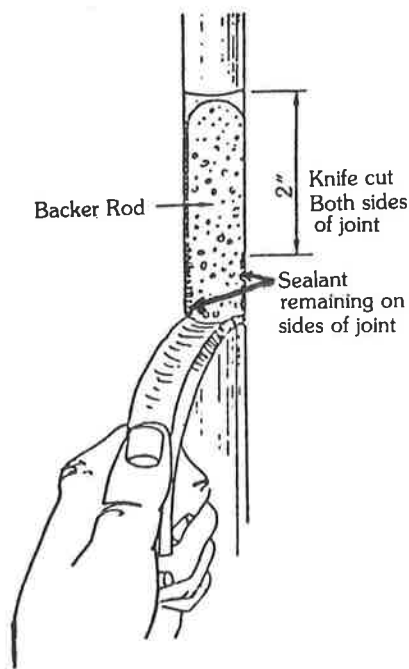

figure 1. low modulus adhesion test

Sealant may be replaced in the test area easily, merely by applying more sealant in the same manner as it was originally installed (assuming good adhesion was obtained.) Care should be taken to assure that the new sealant is in contact with the original and that the original sealant surfaces are clean, so that good bond between the new and old sealant will be obtained.

Vertical Joints

Low Modulus – (figure 1)

1. Grasp the 2 inch piece of sealant firmly between the fingers and pull away from joint at a 90° angle or more, and try to pull the uncut sealant out of the joint.
2. If adhesion is acceptable, the sealant itself will tear before releasing adhesively from the substrate.

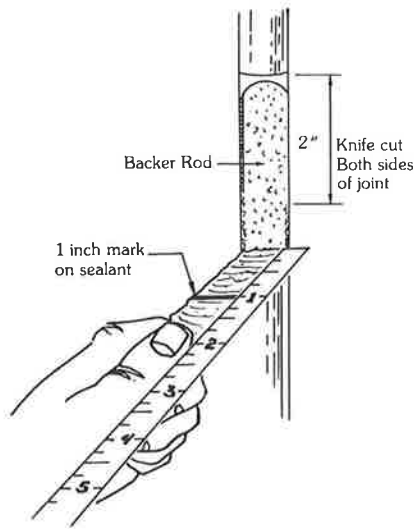

figure 2. high modulus adhesion test

High Modulus – (figure 2)

1. Mark the sealant tab one inch from the bottom.
2. Grasp the sealant firmly between the fingers just above the one inch mark and pull at a 90° angle. Hold a ruler alongside the extended sealant.
3. Pull the tab until the one inch mark on the sealant meets the four inch mark on the ruler. Hold one minute. If the one inch mark can be pulled that far (300% elongation) without the sealant pulling away from the walls of the joint, the sealant will perform in 50% joint expansion.

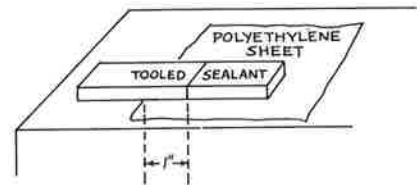

figure 3. test piece for horizontal surface

Horizontal Surfaces

If the test is done on a flat surface, a test piece like figure 3 is recommended. No undercutting is needed since sealants don't adhere well to polyethylene. After cure, follow procedures for high or low modulus sealant on a vertical joint. It is often desirable to submerge the test piece in water for one day or seven days and repeat the pulling procedure. The choice of one or seven days depends on the climate or environment where the sealant is expected to be used.

Taken from the Summer 1984 issue of "The Applicator" a publication of the Sealant and Waterproofers Institute.

Glossary of Sealant Terms

Accessory Materials – Filler boards, bond-breakers, back-up materials and primers.

Acetoxy Cure – A silicone sealant that cures by liberating acetic acid.

Adhesion – That tendency of a material to bond to another substance or material when under a separating stress.

Adhesive Failure – Loss of bond between sealant and substrate where sealant itself remains intact.



Adhesive Failure

Alcohol – Solvent used for cleaning glass, porcelain or some plastics prior to sealing.

Ambient – The temperature of the surrounding air. Used to describe general temperature around the area of work.

Application Life – The period of time during which a sealant, after being mixed with a catalyst or exposed to the atmosphere, remains suitable for application.

Articulated Joint – A joint with movement limited by restraints.

Back-Up Material – Material placed in a joint cavity behind the sealant to control joint depth of sealant without inhibiting joint closure. Often made of polyethylene or polyurethane foam.

“Band Aid” Joint – Sealant joint composed of a bond-breaker tape over the joint movement area with an overlay of sealant lapping either side of the tape sufficiently to bond well to the substrate on each side. Used where extreme movement occurs and conventional joint design is not possible (i.e., metal joints, Deep V joints) or as a correction to existing joints that have failed.

Bead – A strip of sealant applied to a joint.

Bed Joint – A caulking joint that has something embedded in it.

Bite – The dimension of adhesive/sealant that holds the glass to the mullion.

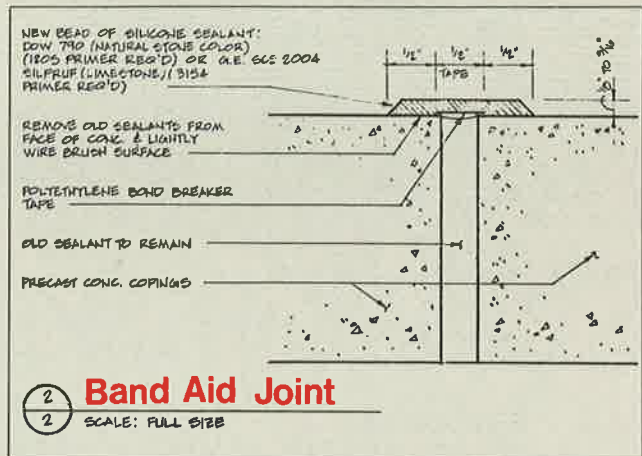

Bond-Breaker – A material used in joints for the purpose of preventing sealant adhesion to the rear joint surface. This allows the sealant to have maximum extension and compression capabilities.

Bulging – Increase in cross-sectional dimension of a sealant under compressive stress.

Butt-Joint – A joint having opposing faces which may move toward or away from each other.

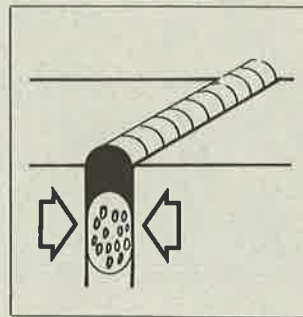

Bulging

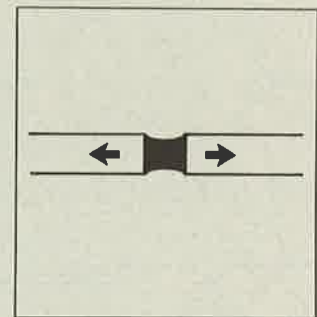

Butt Joint

Caulking – Process of sealing a joint.

Caulking – A material used for joint sealing where minor or no elastomeric properties are required.

Channel – Three-sided, U-shaped member in a sash or frame to receive glass or panel inserts.

Chemically-Cured Sealant – A sealant that cures by chemical reactions, usually involving the formation of cross-linked polymers.

Cladding – Refers to an exterior skin type of a building. Example: glass curtain wall, pre-cast cladding.

Closed-Cell Backer Rod – An extruded polyethylene or polypropylene foam backer rod created by injecting gas into the plastic. The gas is trapped within the cellular structure, giving the backer rod its shape.



Caulking

Coefficient of Linear Expansion – The numeric value which expresses the amount of change in dimension of a substance occurring with a given change in temperature.

Cohesion – That tendency of a material to maintain its integrity without separating or rupturing within itself when subjected to external forces. That tendency to bond within itself.

Cohesive Failure – Rupturing or tearing of sealant material itself without loss of bond to substrate.

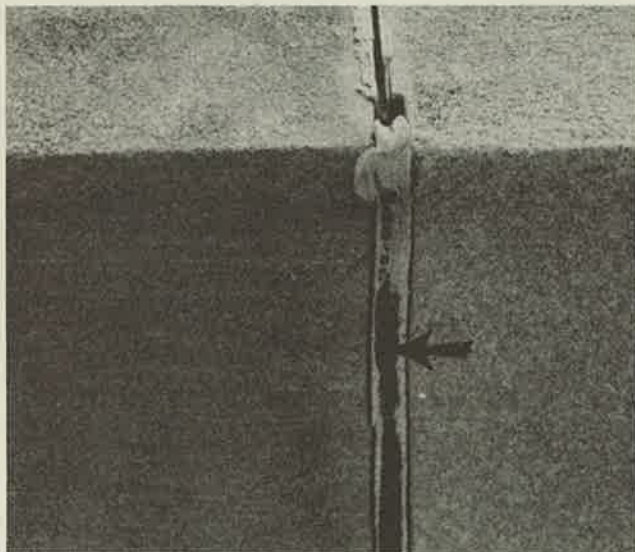

Cohesive Failure

Cold Flow – The change of physical dimensions of a sealant after polymerization or original set has taken place. See Creep.

Compatibility – The ability of materials to be in contact indefinitely without any adverse effect to either. Compatibility does not imply adhesion.

Compression Seal – A compartmentalized or cellular sealant which, under compression between the joint faces, provides a seal.

Compression Set – The change occurring in a sealant, when deformed, that prevents full return to original shape.

Compression Joint – A joint in which the sealant is always subjected to a compression stress due to a closing tendency of the joint faces.

Condensation Cure – Curing upon exposure to humidity or moisture.

Construction Joint – A joint between different materials or between stages of construction, not necessarily intended to accommodate movement.

Contraction Joint – A joint between building components (e.g., newly cast concrete) where the only movement to be expected is due to the shrinkage of either or both components.

Control Joint – Formed, sawed, or tooled groove in a horizontal or vertical surface to regulate the location and amount of cracking and separation resulting from the dimensional change of different parts of a structure.

Coping – The cap or top of a wall which seals the wall cavity and is sloped to shed water.

Craze Cracks – A maze or random pattern of fine cracks in material surface caused by extreme cold, internal stresses, or lack of elasticity under external forces of weathering.

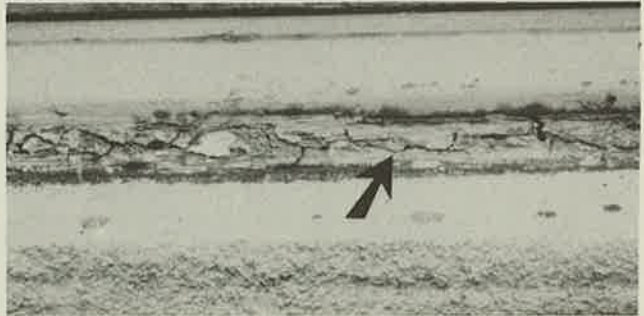

Craze Cracks

Crazing – The development of craze cracks.

Creep – The property of a substance which allows it in time to become permanently deformed when subjected to a stress. Creep is greater at higher temperatures.

Curtain Wall – Type of construction in which walls of the building are non-structural walls usually made of glass/metal and glass, or other composite product panels. Usually they are there for aesthetics only and to keep weather out of the building.

Deform – Change of dimension or shape produced by movement.

Dry Glazing – Glazing technique using compression gaskets for spacers and seals. No sealant is used.

Dynamic Joint – A joint intended to accommodate expansion and contraction movements of the structure.

Elastomer (Elastomeric, Elastic Sealant) – A material which cures to a synthetic rubber material capable of returning to its original dimensions after tensile or compressive forces are applied which are within limits of its yield strength.

Expansion Joint – A joint intended to accommodate expansion and contraction movements of the structure.

Filler Boards – A material generally used in expansion joints primarily to provide support to the sealant so that it can resist pressure from the surface. Filler boards are used to form the joint when one structural component is placed or cast against another. Commonly used materials in the manufacture of filler boards are impregnated fiber or cork boards.

Fillet Bead – A triangular-shaped bead of material used to seal a right-angled joint.

Fronting – Front glazing or front pointing. This is done where two parallel edges have a recess between them, such as a shallow gap between two parallel adjoining window frames, which requires a flexible filler.

Glazing – The process of installing glass in prepared openings in windows, doors, panels, screens, and partitions.

Hinge Joint – Any joint which permits action with no appreciable separation of the adjacent members.

High Modulus – Less elastic (300-500% elongation) and high strength (100-150 psi @ 150% elongation) sealant used for joints with limited movement not exceeding $\pm 25\%$.

Horizontal Joint – Any joint whose central axis lies primarily in the horizontal plane.

Isolation Joint – A joint placed to separate material into individual structural elements, or from adjacent surfaces.

Joint – A discontinuity in the surface at a predetermined position, which may be filled with a sealant or left unfilled.

Joint Movement – The difference in width of a joint opening between the fully open and fully closed positions.

Lap Joint – A joint in which the structural units being joined override each other so that, with movement, the sealant is in shear between the joint faces.

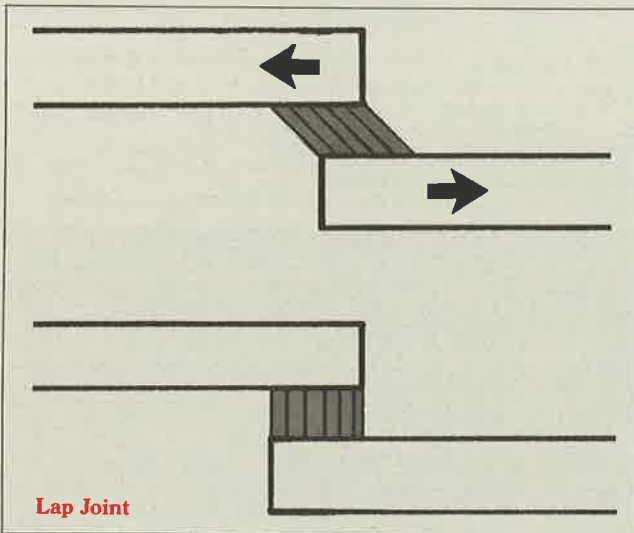

Low Modulus – Highly elastic (elongation greater than 1000%), low strength (20-40 psi @ 150% elongation) sealant used for movement joints where movement can exceed $\pm 40\%$. Not used for structural glazing.

Mastic – A sealant with putty-like properties.

MEK (Methyl Ethyl Ketone) – Solvent used for cleaning glass, porcelain, silicone sealants, or aluminum prior to sealing.

Medium – Usually a liquid or semi-liquid ingredient of a sealant or waterproofing material which controls ease of application, appearance, adhesion, durability and chemical inertness.

Minimum Design Joint Width – A realistic estimation of the width at which a joint should be constructed, obtained by applying manufacturing and constructional tolerances to the minimum theoretical joint width.

Minimum Theoretical Joint Width – The initial approximation of the width at which a joint should be constructed, obtained after consideration of the movements at the joint due to thermal, moisture, and other changes; and the movement capability of a sealant.

Movement Joint – See Expansion Joint.

Naptha – Solvent used for cleaning plastics, lacquered aluminum or red lead primed steel prior to sealant application.

Necking – Reduction in cross-sectional dimension of a sealant under tensile stress. Narrowing down to an hourglass shape.

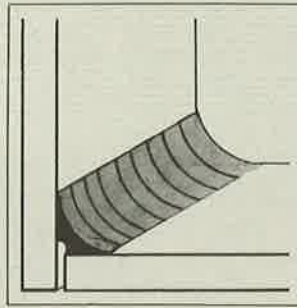

Fillet Bead

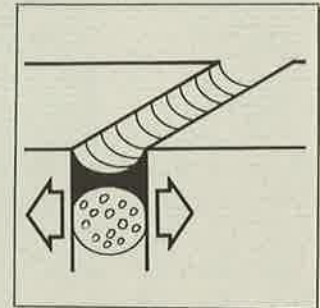

Necking

Neoprene – A synthetic rubber having physical properties closely resembling those of natural rubber but not requiring sulfur for vulcanization. It is made by polymerizing chloroprenes (a synthetic rubber).

Neutral Cure – A sealant that cures with no corrosive by-products.

Non-Movement Joint – A joint designed for minimal or no movement.

Non-Sag Sealant – A sealant formulation having a consistency that will permit application in vertical joints without appreciable sagging or slumping at temperatures between 40°F and 100°F.

Octoate Cure – A condensation cure which releases methyl alcohol vapor during curing.

One-Part Sealant – A chemically-curing sealant containing a reactive polymer base which cures upon exposure to the air and/or humidity. It requires no mixing.

Open-Cell Backer Rod – A round, flexible, polyurethane foam backer rod which relies on its chemical and physical make-up to attain its shape.

Outgassing – A problem that exists when the cells in a closed-cell backer rod rupture, allowing trapped gases to escape to the atmosphere and causing loss of volume in the backer rod, and possible joint failure.

Perimeter (Peripheral) Joint – A joint formed by the outer edge of one panel or material and the leading edge of another.

Pointing – Finishing of joints in a brick or stone wall, normally using mortar as the fill.

Polybutylene – A light colored liquid straight chain aliphatic hydrocarbon polymer. Widely used as a major component in sealing and caulking compounds (made up of many different synthetic rubbers).

Polysulfide Polymers – Long chain aliphatic polymers containing disulfide linkage combined to make an elastic rubber type material.

Pot Life – See Application Life.

Primer – A material applied to joint faces to improve the bond (adhesion) of sealants.

Raking Out – Cutting out of joints in preparation for caulking.

Reglet – A groove or recess cut into the face of a surface.

Return – The continuation of a molding, projection, member, or cornice or the like in a different direction, usually at a right angle.

RTV (Room Temperature Vulcanizing) – Becoming rubber at ambient temperatures.

Sag – Flow of an uncured sealant within the joint resulting in loss of the sealant's original shape.

Seal – A generic term for any material or device that prevents or controls the passage of matter.

Sealant – An elastomeric material with adhesive qualities that joins components of a similar or dissimilar nature to provide an effective barrier against the passage of the elements.

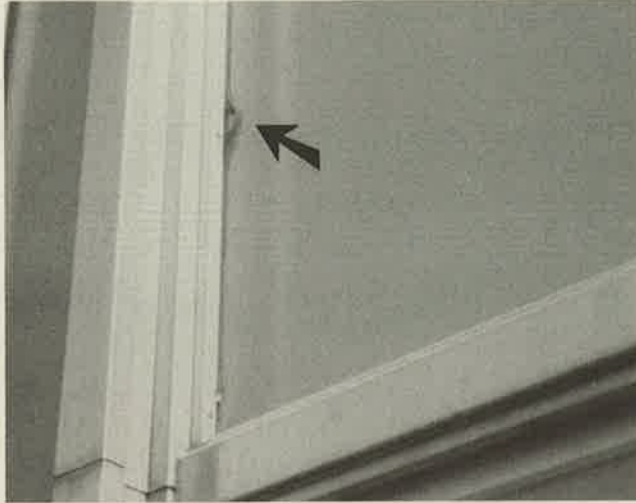

Sag

Sealant Reservoir – Cavity, indentation, channel, or formed joint into which the sealant is placed.

Self-Leveling Sealant – A sealant formulation having a consistency that will permit it to achieve a smooth level surface when applied in a horizontal joint at temperatures between 40°F and 100°F.

Shear – The strain in or the failure of a structural member at a point where the lines of force and resistance are perpendicular to the member.

Shearing Joint – A joint in which one opposing face may move parallel to the other.

Shearing Stress – An action or stress resulting from applied forces which tend to cause two contiguous parts to slide relative to one another in a direction parallel to their plane of contact.

Silicone – One of the family of polymeric materials in which the receiving chemical group contains silicone and oxygen atoms as links in the main chain.

Skinning Over – Curing of outer surface of sealant.

Sliding Joint – Similar to fillet in shape except that it is a moving joint in the corner of which backer rods should be placed before the sealant is applied.

Slump – See Sag.

Spalling – Splintering or chipping of a joint face or edge.

Squeeze Out – Extrusion of sealant from joint due to excessive compressive stress.

Staining – A change in color or appearance of masonry adjacent to the sealant.

Static Joint – Same as non-movement or non-working joint.

Strip Sealant – Cellular or elastic compression seal which must be cut, then heated with approved hot iron to form corners.

Structural Glazing – Glazing technique where glass lites are adhered directly to a mullion by a sealant.

Substrate – The surface to which a sealant is applied and must bond.

Tack-Free – A condition where the sealant surface is no longer sticky.

Tensile Strength – Resistance of a material to a force that tends to pull it apart, usually expressed as the measure of the largest force that can be applied in this way before the material breaks apart.

Tensile Stress – Stress resulting from a stretching force.

Theoretical Joint Width – See Minimum Theoretical Joint Width.

Thermoplastic Sealant – A material which becomes more plastic and less elastic with a rise in temperature. The change of properties with heat is reversible over many heating cycles.

Thermosetting Sealants – A material which cures or achieves its desired properties by a heat-induced chemical reaction which is not reversible.

Three-Part Sealant – A chemically-cured sealant supplied in three parts, one containing the reactive polymer base, one its curing agent, and one the color agent. Usually supplied in separate containers. The parts must be thoroughly mixed together before use.

Tooling – Smoothing and shaping the surface of a sealant and firming it into the joint.

Two-Part Sealant – A chemically-cured sealant supplied in two parts, one containing the reactive polymer base and the other the curing agent. It may be supplied in separate containers or in the same container, but separated by an inert layer. The parts must be thoroughly mixed together before use.

Ultimate Elongation – Stretching sealant until failure.

Urethane – A generic term for ethylene carbonate. The material is used extensively for a base polymer in elastic sealants and waterproofing.

Vertical Joint – A joint whose central axis lies primarily in the vertical plane.

Water-Miscible – Water soluble (easily mixed with water).

Weep – Opening in a cavity wall to collect moisture and dispense it or to put breathers in sealant to relieve moisture.

Wet Glazing – Construction technique using a bead of sealant to weather-seal and adhere the lite in the glazing channel.

Wind Loading – Total force exerted by the wind on a structure or a part of a structure on a building component. Usually used in the form of test to determine how much wind a certain type of window or wall can withstand in order to meet certain criteria.

Working Joint – See Expansion Joint.

Work Life – See Application Life.

Xylene – Solvent used for cleaning lead or steel prior to sealing.



Squeeze Out

Glossary is published by Hoffmann Architects, specialists in investigative and rehabilitative architecture/engineering. Our offices are located at 3074 Whitney Avenue, Hamden, CT 06518 Phone (203) 281-4440 and 1925 Century Boulevard, Suite 4, Atlanta, GA 30345 Phone (404) 633-7817.

technical notes

Questions and Answers

Question – What are the differences between adhesive and cohesive failure and what causes them?

Answer – An adhesive failure occurs when the sealant pulls away from the substrate. A cohesive failure is when the sealant itself tears or rips but still remains bonded to the substrate. Some deficiencies in joint design or sealant application can cause either or both types of failure. These include excessive movement of the joint for the type of sealant used, too thick of a bead, lack of a bond breaker, improper shape of bead, and application of the sealant at low temperatures. In addition, cohesive failure may occur due to physical abuse. Most adhesive failures are due to improper or poor surface preparation such as not priming the surface where it is required or not cleaning or drying the surface. Other causes are incompatibility problems between the sealant and substrate, exposure to ultraviolet light, weak substrate, and aging or hardening of the sealant.

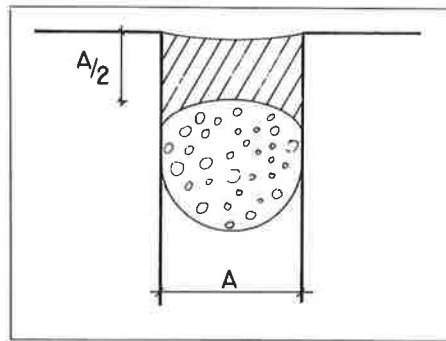

figure 4. optimum joint depth

Question – What is an “acetoxo” sealant?

Answer – Acetoxo sealants are silicone sealants that liberate acetic acid while curing. These sealants are identifiable by the vinegar-like odor that is generated. (Vinegar is 10% acetic acid.) Some examples of acetoxo sealants are Dow-Corning® 999, General Electric® SCS1200 and SCS1000, Rhodorsil® 3B and Tremco® Proglaze silicone sealants.

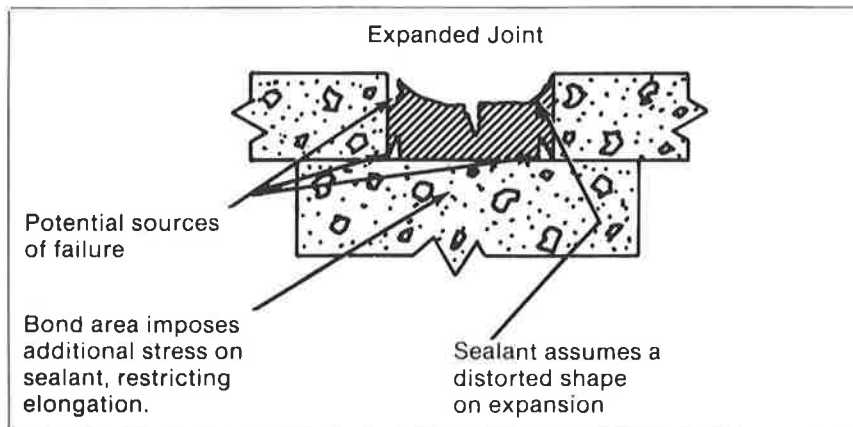

figure 5. adhesive and cohesive failure of sealant due to three sided adhesion.

Question – If a thin bead of elastomeric sealant makes a good joint seal, wouldn't a thicker bead be better?

Answer – No. Joint depth directly affects the performance of a sealant joint. The volume of sealant affects the sealant's ability to stretch and its tolerance to stretching. Like a rubber band, the thicker the sealant, the more difficult it becomes to stretch it and the less it will do so. The more difficult it becomes to stretch, the more stress is put on the bond line of the sealant, making it more susceptible to adhesive failure. The less tolerant of stretching it becomes, the more susceptible it becomes to cohesive failure as the movement of the joint can rip the sealant apart. The optimum depth of the sealant bead is $\frac{1}{2}$ the width of the joint, with a minimum depth of $\frac{1}{8}$ inch. (figure 4)

Question – Why is backer rod used?

Answer – Backer rod is used for several reasons. It is used to limit the depth of the joint so that the sealant depth does not exceed $\frac{1}{2}$ of the joint width. Second, it is used to provide support for the sealant during application and tooling. Third, the backer rod often acts as a bond breaker. A bond breaker limits adhesion of the sealant at the base of the joint. When a sealant is adhered on three sides, its movement is restricted with subsequent adhesive and/or cohesive failure (see figure 5). Finally, a polyurethane foam backer rod can add some insulating value to the joint.

services

Representative Projects

Hoffmann Architects has been involved in projects requiring expertise in several specific disciplines. These recent projects range in location from Florida to Massachusetts.

We are currently reviewing and analyzing the fire and life safety regulations and building code requirements of a 350-room inn located in northern Maryland. This project will include preparing plans and specifications for improvements to fire and life safety provisions and coordinating the construction of remedial work. The firm is performing a similar life safety survey of a nearby office building for the same client.

Recent real estate consulting services include performing pre-purchase building condition surveys of a 41-story office building in Boston, Massachusetts for a group of institutional investors; a 450,000 square foot office building in Tysons Corner, Virginia for an insurance company; and an office building in North Haven, Connecticut for the accounting firm of Kelleher & Elia. We are conducting a pre-mortgage survey of a large medical office building in New Haven, Connecticut for The Travelers Companies Real Estate Investment Department. For Massachusetts Mutual Life Insurance Company, the firm performed a pre-mortgage survey of a 24 story office building in New York City.

Continuing our work for the Southern New England Telephone Company, we recently performed a survey of the entire building envelope of one of their Central Office Buildings in New London, Connecticut.



Jack Van Jeune (upper right) monitors testing of masonry anchors

The firm is preparing plans and specifications for reroofing and rehabilitating the brick and limestone parapets on historic Radio City Music Hall in New York City. Hoffmann Architects is also preparing plans and specifications for reroofing the remaining 101,500 square foot section of Ridgefield High School in Ridgefield, Connecticut.



Marty Benassi, project architect, with drafter Laurie Janul



The Southeast Region Office of Hoffmann Architects will be reviewing plans and specifications and monitoring the construction of a nine-building office complex in St. Augustine, Florida, for the Broadview Savings and Loan Company.

If you would like more information on the services we offer, please contact Nancy H. Bostwick in the Connecticut office or Karen L. Warseck in Georgia.

technical notes

Single-Ply Stands Up To Simulated Winds In Test

Single-ply, sheet rubber roofing fared well in simulated winds of nearly double hurricane force during recent tests conducted on behalf of the International Congress of Building Officials (ICBO).

The tests, performed by engineers of the Goodyear Roofing Systems Division in Akron, OH, generated winds up to 125 mph across a 120-square-foot roof surface. The high winds were created by using two 72-inch fans powered by 250 horsepower engines.

"The angle of wind attack was held at a critical 45 degrees to the building corner to provide maximum wind effect during the test," said Paul Oliveira, Goodyear's chief engineer for roofing systems. "We evaluated the maximum wind speed criteria for conventional roofing ballast like that used on most loose-laid roofing systems, as well as various sizes of ballast stones and lightweight, interlocking concrete paver blocks."

Oliveira said that based on the results of the recent wind tests, established standards on ballast movement in high winds needs re-evaluation. The tests were conducted because ICBO is attempting to establish single-ply, sheet rubber roofing specifications for building codes in the western United States.

New standards should also include both the size of ballast stones and the roof's applied weight, Oliveira said. Engineers learned from the wind tests that the rate of scour – when the wind pushes ballast rock around the roof –

depends on stone size and weight, as well as wind speed.

"Larger-sized ballast stone will redistribute itself on the roof under high winds," Oliveira said. "Smaller stones could become airborne and fly off the roof."

With the interlocking, lightweight concrete pavers, however, no movement appeared during the tests at the maximum wind speed of 125 mph. That lack of movement is expected to be a major consideration in ballasted roofing system design in areas where high winds are common.

Reprinted with permission from Contractors Guide, 5520-G Touhy Ave., Skokie, IL 60077.



ballasted roof

While Hoffmann Architects/Journal attempts to provide the most accurate information on general subjects, it is not intended to be a substitute for professional architectural/engineering services. We strongly urge you to consult a qualified rehabilitation architecture/engineering firm (ours) for answers to specific questions.

Plywood Alert Update

In the Plywood Alert in the first issue 84 of Hoffmann Architects/Quarterly, we mentioned that roofs using $1\frac{5}{32}$ inch thick plywood in deck assemblies calling for $\frac{1}{2}$ inch panels may not be insurable. Since then, Underwriters Laboratories (UL) has announced that the thinner material would be an acceptable substitute. According to Robert Donahue, assistant managing engineer at UL's Fire Protection Department, the use of the thinner plywood "would not adversely affect the Class A, B or C fire resistance roof covering classifications."

However, the Asphalt Roofing Manufacturers Association still had some concern about excessive deflection and refused to accept the $1\frac{5}{32}$ inch plywood, deciding instead to leave acceptance of the panels up to the individual manufacturers. So, before installing the $1\frac{5}{32}$ inch thick plywood as roof decking, the manufacturer of the membrane system to be installed should still be contacted to confirm that the roof can be warrantied.

In regard to code acceptance of the thinner panels, the American Plywood Association has been performance testing the $1\frac{5}{32}$ inch material and has rated the tested panels $\frac{3}{16}$, the same grade as many $\frac{1}{2}$ inch thick boards. However, as an example, the Standard Building Code uses both the APA grading and the board thickness in determining allowable spans for plywood roof sheathing, an ambiguity that requires consultation with the local building official to resolve.

staff and technical notes

Sealant Alert

The two-part silicone glazing sealant used in the manufacture of dual seal insulating glass units may be a source of premature failure of the units.

A dual seal insulating glass unit is, in essence, an air space sandwiched between two layers of glazing and secured at the perimeter by a double seal. (figure 6) The primary seal consists of a desiccant-filled, aluminum or galvanized steel spacer. The secondary seal is made of the two-part glazing sealant which not only provides weather resistance, but also structurally bonds the individual components together.

When the insulating glass unit containing the two-part silicone glazing sealant is installed, it can come into contact with or be adjacent to another sealant used as weatherseal, toe bead, heel bead or as an adhesive in structural glazing. If that sealant is an acetic-acid-liberating (acetoxy) silicone sealant, an incompatibility problem can occur that can cause the two-part silicone glazing sealant to lose adhesion to the glass or metal. If the adhesion fails, the unit can disassemble and its pieces fall.

The potential for this problem can be eliminated by careful specification of the installation sealant. A neutral cure silicone sealant (one that does not form a corrosive by-product such as acetic acid during curing) should be specified to avoid this cause of adhesive failure. Installation of the proper sealant can be easily monitored, since an acetoxy sealant will generate a vinegar-like odor during curing. Careful joint design and proper surface preparation

Staff News

Hoffmann Architects is pleased to introduce the newest members of our firm:

Stuart Tillinghast, AIA, CSI has joined the firm as Project Architect with responsibility for survey reports, design of remedial work and project administration. A graduate of Yale University, he is a member of the American Institute of Architects, Construction Specifications Institute and Connecticut Building Congress.

Bruce R. Soden is our new Structural Technician and Drafter. He attended Newark College and is experienced in structural detailing and drafting and investigative field work.

Martin A. Benassi, AIA spoke at a seminar on project representation sponsored by the Connecticut Society of Architects. His topic was "The Project Representative in the Field" and included how unforeseen circumstances are handled by the project representative and the use of daily field reports.

Harwood W. Loomis, AIA attended a comprehensive workshop in Denver, Colorado on asbestos. The workshop covered such subjects as assessing the hazard and the various options for dealing with it. The seminar was sponsored by the American Wall and Ceiling Institute.

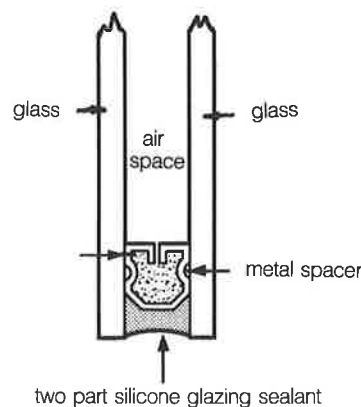

figure 6. dual seal insulating glass unit

and sealant application are also necessary to assure that adhesive failures of the window wall will not occur.

Journal is a publication of Hoffmann Architects, specialists in investigative and rehabilitative architecture/engineering, including the analysis and solution of roofing, masonry, glazed curtain wall and structural problems. Our offices are located at 3074 Whitney Avenue, Hamden, CT 06518, Phone (203) 281-4440 and 1925 Century Boulevard, Suite 4, Atlanta, GA 30345, Phone (404) 633-7817.

We welcome contributions to HAJ from our clients and friends. Please send news and technical information to Karen L. Warseck, Editor, Hoffmann Architects/Journal at the Atlanta address. Address changes and additions to the mailing list should be sent to Nancy H. Bostwick in Hamden.