

**Hoffmann  
Architects**

Journal of architectural  
technology published by  
Hoffmann Architects, Inc.,  
specialists in the rehabilitation  
of building exteriors.

# Journal

## Storefront Rehabilitation and Design

Juan A. Kuriyama, AIA and Tai Mahmuti, B. Eng., LEED Green Associate

Walk down any main street in America, and the first thing that draws the eye are the colorful and lively storefronts of the shops and businesses lining the road. While skyscrapers might define a city from a distance, what distinguishes neighborhoods at street level are the styles and architectural features of its storefronts.

windows and doors that drew no more prominence than those of main street homes. By the 19th century, larger commercial buildings had more distinct ground floor facades, with regularly spaced stone or brick piers and larger windows made up of small panes, though entrances still held little special prominence in the design.

With the advent of architectural cast iron in the later part of the 19th century, combined with advances in glass manufacturing, storefront design was revolutionized. Slender metal columns and large areas of glass enabled shopkeepers to readily advertise their merchandise, with daylight reaching far into the space to illuminate the shop within. So began the modern commercial district: bright, expansively windowed storefronts collected along main thoroughfares, establishing what would become the central organizing feature of cities and towns.



▲ Storefronts are the defining features of streetscapes and neighborhoods.

Long before we came to know cities by their signs, lights, and window displays, the first settlements and burgeoning townships of early America began to coalesce around centers of trade and industry. Scarcely distinguishable from their residential neighbors, the shops of 18th century America alerted potential customers to their wares through signs and awnings, with

By the mid-1800s, cast-iron storefront elements, such as sills, lintels, and columns, could be ordered directly from manufacturer catalogs, with standard configurations available as complete assemblies. While little changed in storefront design around the turn of the century, save the addition of electric lights, the 1920s and 30s saw an explosion of materials and features, from aluminum and stainless-steel

*Juan A. Kuriyama, AIA, Vice President and Director of Architecture, manages project teams in the assessment, rehabilitation, and design of building envelope systems. Tai Mahmuti, B. Eng., LEED Green Associate, Project Manager, develops building enclosure solutions to meet demanding performance objectives.*

framing to glass block and neon. Design elements were streamlined, with stylized signage that was often integral to the fascia. Storefronts, in short, became what we know them as today: architectural features that are extensions of the businesses within, and which function in communication with the people and buildings that surround them.

Rehabilitation and design of storefront systems demands consideration of many factors, from thermal performance and operability to historic landmark sensitivity and appearance. With large sheets of glass, storefronts maximize light and views, but less wall area also means it is more difficult to keep out the elements. Storefront design is a balance between aesthetics and performance. Heat transfer, glare, condensation, and air and/or water infiltration are challenges for storefront assemblies. While it may seem straightforward to choose an assembly from a manufacturer's collection, finding the right system for the situation takes thoughtful evaluation.

### Storefronts, Curtain Walls, and Window Walls: What's the Difference?

From an architectural standpoint, **storefront** means not necessarily the entrance to a shop, but a type of wall assembly, which can be used in a variety of applications. Storefront systems are typically limited to the ground floor; no more than 10 or 12

feet in height. The North American Fenestration Standard (NAFS) defines storefronts as non-loadbearing commercial entrance assemblies, typically spanning between the floor and the structure above (AAMA/WDMA/CSA 101/I.S.2/A440-11). Storefronts tend to have shallow framing profiles, with glass that is usually centered in the assembly but may be offset to the front or back.

Like storefronts, glazed **curtain walls** are non-loadbearing assemblies, but unlike storefronts, they can span multiple floors. Curtain wall framing members run past the face of floor slabs, such that the assembly hangs from the outside of the building structure, like a curtain. Since curtain wall systems are designed to perform as multi-story facade assemblies, they must meet additional demands for differential movement, seismic forces, air and water infiltration, thermal expansion and contraction, deflection, and other performance criteria, all of which also play a role in storefront design.

**Window walls**, a third type of non-loadbearing fenestration system, span from the top of one floor slab to the underside of the one above, and they provide an alternative to curtain wall for applications above the ground floor. The large windows are anchored at the head and sill to the building structure, and receptor systems accommodate movement and provide for drainage.

Of the three systems, storefronts

generally provide the most cost-effective option for ground-floor applications, both for traditional retail settings and for a variety of commercial and institutional structures.

### Components of Storefront Systems

The two primary components of a storefront system are the fixed elements, including framing and glass, and the operable features, primarily doors.

#### Glazing

For storefronts, glass may be monolithic or may consist of two or more panes of glass separated by a spacer material, which is commonly referred to as an insulating glazing unit (IGU). Monolithic glass can be used in butt-joint systems, where glass lights are supported only on two sides, with structural silicone sealant between panes. Where additional support is required, monolithic glazing assemblies may incorporate point anchors and cables.

IGUs must be supported on all four sides. While this could entail metal framing, intermediate mullions may instead consist of glass or metal fins, internal mullions, or a combination of these.

#### Framing

Modern storefront framing is often extruded aluminum, which is lightweight, durable, and highly resistant to corrosion. Steel may be used for applications where its superior strength is advantageous, so framing dimensions may be reduced for improved sightlines. In historic buildings, storefronts may be composed of wood or a variety of metals, including cast iron, galvanized sheet iron, bronze, copper, tin, cast zinc, and stainless steel.

Conventional storefront systems are **stick-built**, constructed in the field from individual framing components



**A** Investigation of the poorly functioning revolving door at this office complex revealed extensive corrosion.



that are assembled and sealed on site. Some new systems are available as **unitized** assemblies, which are factory-assembled and glazed into units, providing controlled conditions for critical seals and reducing installation time. However, stick-built storefronts are more forgiving during construction, as unitized assemblies have low critical tolerances and demand accurate field dimensions.

### Flashing

Essential to controlling moisture infiltration, sill flashing is a critical part of storefront assemblies. Unlike a curtain wall system, which moves water through weep holes at each light of glass, storefront assemblies direct all water to the sill. Weep holes along the outer edge of the sub-sill allow moisture to drain to the exterior.

At jambs, end dam flashing prevents water from infiltrating into adjacent wall assemblies. Water deflectors at intersections of vertical and horizontal elements keep moisture from settling on top of the glass, where it can lead to glazing seal failure and leaks.

### Doors

Subjected to external and internal air pressures created by wind, the heating, ventilation, and air conditioning system (HVAC), seasonal variability, and extreme weather events, doors must be durable and readily maintainable. Air infiltration is a primary concern, so weatherstripping should be installed along the perimeter. Storefront doors might be selected from a different manufacturer than fixed units, so compatibility is a key consideration.

When specifying doors, design professionals must consider not only aesthetics and resilience, but also code requirements and anticipated traffic. Regulations for occupancy load and accessibility may affect the selection process. Options include:

## Example Section of Storefront Sill Assembly

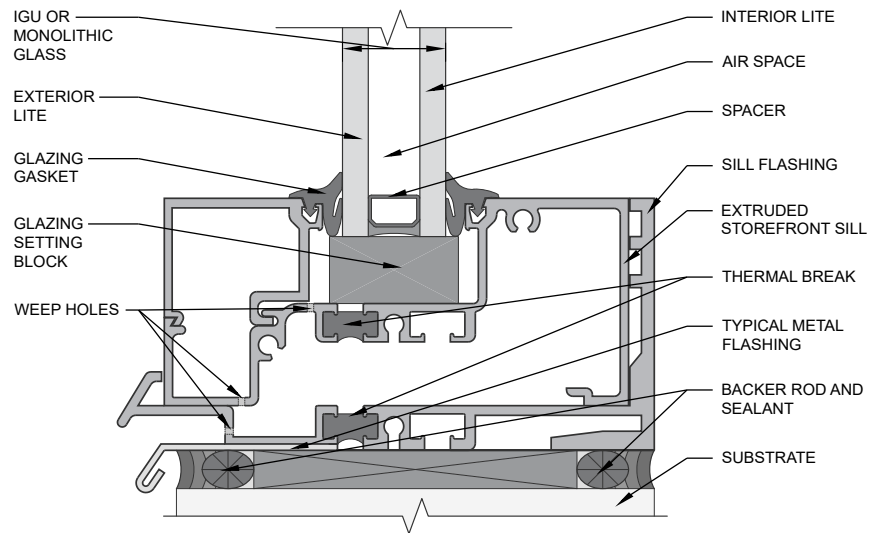

ILLUSTRATION: STEFFANY MALARIK

**Hinged doors.** The traditional type of door used in both residential and commercial construction, hinged doors are held up by hinges along the side of the frame. They swing in one direction only.

**Pivot doors.** Common in retail applications, pivot doors are secured to a pivot box, or central hinge, on the floor. Pivot doors can open a full 180 degrees, so they swing in both directions, and the hardware permits a frameless glass panel to act as the entry door.

**Balanced doors.** Equipped with double-pivoted hardware, balanced doors are partially counterbalanced to provide easier operation. Ideal for areas with high wind pressures, balanced doors integrally control the closing of the door, negating some of the effects of strong wind conditions.

**Revolving doors.** For buildings with significant traffic, such as commercial buildings, hotels, shopping malls, or hospitals, revolving doors can mitigate strong positive and negative pressures. Where HVAC and outdoor conditions would cause excessive wear

and tear on a typical door, revolving doors permit high-volume usage without compromising indoor climate. Automatic revolving doors provide ADA-compliant operation while managing heavy traffic.

For lower-intensity settings where weather exposure and drafts are considerations, such as restaurants, commercial institutions, and shops, **vestibules** can moderate temperature differentials and wind conditions. Some energy conservation codes require vestibules for certain types of new construction. To limit heat transfer at entry points, existing buildings may be retrofitted with vestibules.

### Design Considerations for Storefronts

Whether for new construction or for the rehabilitation or replacement of existing assemblies, storefront design must consider myriad factors, from appearance and durability to energy efficiency and deflection.

#### Thermal Performance

As energy codes become increasingly stringent, all elements of the building

## Storefront Performance Testing

Performance testing of new storefront assemblies may be mandated by code. In addition to manufacturer certification of individual components, mock-ups of project-specific storefront assemblies may be evaluated in a testing facility to confirm performance requirements are met.

A typical testing program might include analysis of:

- Air infiltration (ASTM E283),
- Water penetration resistance – uniform static air pressure (ASTM E331),
- Water penetration resistance – dynamic pressure (AAMA 501.1),
- Deflection (ASTM E330),
- Thermal cycling (AAMA 501.5), and
- Condensation resistance (AAMA 1503.1).

In addition to the above, the design professional may recommend optional testing for:

- Forced entry resistance (AAMA 1302.5),
- Acoustic performance (ASTM E90 and ASTM E1332), and/or
- Condensation resistance – computer simulation (NFRC 500).



Field tests confirm the storefront meets performance standards.

Depending on the complexity of the design, the architect or engineer may recommend testing of the entire storefront system, including all components and glazing. The testing laboratory provides a basic structural skeleton, on which the contractor/installer builds the test specimen under the direction of the manufacturer. Since minor modifications are often necessary to pass the performance tests, it is important to have participation of the installer as well as all manufacturers, especially for custom assemblies involving parts from different companies.

In-situ field testing is often recommended to confirm the installed assembly performs as expected. ■

(continued from page 3)

envelope, including storefronts, must be designed for energy efficiency.

**Thermal bridging**, the transfer of heat energy through conductive materials in an assembly, is a primary consideration for storefronts. Framing materials like aluminum and steel have high heat transfer coefficients, so storefronts must incorporate low-conductivity barriers that act as **thermal breaks** between exterior and interior, blocking the path of energy transfer across the wall assembly.

Model codes, such as the International Energy Conservation Code (IECC), and standards, like ASHRAE 90.1, call for energy modeling and performance testing for new or substantially renovated storefront assemblies. In some jurisdictions, local codes may prescribe even more rigorous testing and higher insulating values than the national standards.

For aluminum-framed storefronts, an additional thermal consideration is expansion and contraction. Aluminum has a high coefficient of thermal expansion, so changes in frame dimensions in response to fluctuating temperatures are a significant consideration. To accommodate thermal changes, larger aluminum storefronts should incorporate expansion joints.

### Wind Load

The potential for deflection and bending in strong winds, which can lead to glass breakage, is a critical design consideration for glazed facade assemblies. Storefronts with larger panes of glass not only afford expansive views, they have fewer joints and therefore better water penetration resistance. However, the larger the window, the greater the potential for higher deflection.

Wind loads are determined by standard calculations per building code and/or by wind tunnel modeling. Industry standards, based on ASTM E330, limit maximum allowable deflection to  $\frac{3}{4}$  inch or the framing span divided by 175, whichever is less.

Glazing size is typically limited by manufacturer capabilities. Wind loads play a role in glazing thickness.

Anticipated wind loads dictate not only glazing properties, but door design, as well. If the pressure difference between the building interior and exterior is too great, doors can be difficult to open or close. Balanced doors can assist in entrance operability.

### Weight

For large sheets of glass, particularly IGUs, glazing weight is an important design consideration. Double- and triple-glazed units can be heavy, so

framing and fittings need to be designed accordingly, which may require steel reinforcement within the storefront extrusion. At doors, jamb framing may need to extend to the head of the storefront framing for structural support, depending upon the type of door, operability, and weight.

### **Moisture Penetration**

Storefronts set back from the face of the building or protected by awnings, canopies, or overhangs tend to perform better in terms of water infiltration resistance than those directly exposed to the elements. Flashing and perimeter details should channel water down and out, to weep holes at the outer edge of the sub-sill. Integral water diverters / deflectors within framing members should direct moisture to the base of the assembly. For perimeter seals, service life varies by material, typically 10 to 20 years, after which seals must be evaluated and monitored for possible repairs or complete replacement.

### **Condensation**

To achieve the clean, modern look of butt joint glazing, which eliminates the intermediate mullion, manufacturers recommend using monolithic glass. However, especially when the frame lacks thermal breaks, monolithic glazing assemblies are prone to condensation.

To dry condensation, especially in winter, additional ventilation is necessary, and possibly perimeter heating. Insulating assemblies and thermal breaks not only protect against energy loss, they prevent condensation, an unsightly nuisance and ongoing maintenance issue.

### **Sound Transmission**

Particularly in the city, noise reduction is essential, and protecting occupants from sound, as well as preserving privacy, is an important

property of the building envelope. The Sound Transmission Class (STC) and Outdoor Indoor Transmission Class (OITC) of an exterior wall configuration are measures of its ability to attenuate sound. STC measures mid- to high-frequency noise, such as conversation and office equipment, and OITC encompasses lower-frequency sounds, such as traffic. The higher the rating, the better the material is at resisting sound transmission.

### **Surrounding Elements**

The relationship of a storefront to the rest of the facade, as well as to the adjoining sidewalk or plaza, impacts the design approach. Provisions must be made for the removal, repair, and waterproofing of sidewalk or plaza paving systems, as well as for disruption to underlying sidewalk vaults or other below-grade spaces. Sidewalk or plaza waterproofing should tie in with storefront flashings, where possible.

### **Safety and Resiliency**

Since storefronts are on the ground floor, they are subject to more wear and tear than the rest of the building envelope. Usage, traffic, and the potential for vandalism may impact the selection of fixtures and finishes.

To resist forced entry, storefronts may incorporate impact-resistant windows. These glazing products incorporate two or more panes bonded with a laminated interlayer, designed to hold together and protect occupants in the event of an impact.

In hurricane-prone regions, impact-rated windows provide protection from windborne debris and strong wind pressures without the need for storm shutters. Building codes and test standards continue to be developed to keep pace with developments in storm safety.

### **Landmarks**

For designated local or national landmarks or buildings that are part of a historic district, storefront design may require approval from the state historic preservation office (SHPO), city landmarks or historic preservation commission (HPC), or other authority. Repairs to historic storefronts may be exempt from compliance with the energy code; historic exemption rules vary by jurisdiction.

Where a historically significant storefront is too deteriorated to restore, the replacement storefront should be in keeping with the character and style of the building and, where applicable, the surrounding streetscape. The National Park Service Preservation Brief, "Rehabilitating Historic Storefronts," provides guidelines for evaluating, restoring, and, where necessary, replacing storefronts from a range of historical periods.

### **Cost**

When evaluating storefront design options, it is important to consider not only up-front cost, but maintenance and operation costs, as well. For example, a pivot door might be



Replacement of this aging storefront (*below*) demanded modifications to the new assembly (*left*) for operation in strong wind.



selected over a balanced door due to its lower cost. If the building is situated in a high-wind zone, the door will be subjected to strong forces when open, taxing the hardware and leading to constant maintenance repairs or replacement. In this location, a balanced door, while more expensive at the outset, might prove less costly in the long term, as its resistance to wind pressure could mean longer lifespan and fewer repairs.

The same could be said of insulating glass and frames with thermal breaks, both of which are generally costlier than their monolithic, un-insulated counterparts. The initial expense might be higher, but the savings in HVAC operation might offset the upfront cost.

### Evaluating and Treating Problems

Whether restoring a historic storefront or locating the source of persistent problems in a newer assembly, the first step in developing a repair program is to closely assess the entire system. Beginning with an inventory of construction materials and styles, the evaluation should consider the storefront's various architectural features, including glazing, framing, support columns/piers, doors and entrances and surrounds, vestibules (if present), ornamentation, and finishes. In some cases, evaluation may require invasive probes to uncover hidden conditions, such as flashing details.

A comprehensive investigation should consider not only the storefront itself, but the relationship of the storefront to upper stories and the adjoining sidewalk, as well as adjacent systems.

### Classifying Deterioration

Particularly for historic storefronts or older assemblies suffering from deferred maintenance, it may be helpful to categorize problems by severity. Prioritizing repairs assists with budgeting, should the work need to be



Without weatherstripping, these doors look sleek, but air infiltration may be an issue.



Vestibules prevent drafts and heat loss.

phased over time.

**Mild deterioration.** For surface issues such as minor corrosion, joint sealant deterioration, or flaking paint, maintenance-level treatments may be all that's needed to restore these elements to sound condition and extend their service life.

**Moderate deterioration.** Leaks may be traced to damaged or improperly constructed flashing, missing overhangs, incorrectly sloped sub-sills, worn gaskets or weatherstripping, or other conditions in need of repair. Isolated sections of material may require repair or limited replacement.

**Severe deterioration.** Where elements are deteriorated beyond repair, they must be replaced. Water infiltration, differential movement, settlement, lack of maintenance, faulty design or construction, and vandalism are all common causes of component failure.

Identifying existing conditions serves to determine the nature and extent of rehabilitation work needed.

### Repair or Replace Decision

Based upon the severity of deterioration, anticipated cost of rehabilitation, and aesthetics, it may prove more desirable to replace the storefront with a new, energy-efficient design. On the other hand, if the storefront is an exemplar of its period and/or part of the architectural character of the building, it may be better to restore existing elements, replacing those that are no longer repairable with closely matched materials.

Factors to consider when determining whether to restore an existing storefront or replace it might include:

**Historic significance.** If sensitively restored, a distinctive historic storefront can enhance the value of the building. Not only does preservation of a period storefront establish the character of the building, it contributes to the ambiance of the neighborhood.

**Condition.** The level of deterioration of a storefront can guide repair-or-replace decisions by establishing a baseline estimate for the cost of repairs. Once deterioration is severe and pervasive, it may be more viable to replace all or part of a storefront than to coordinate extensive repairs. Note that for historic or landmark buildings, even if the storefront is in poor condition, the HPC or SHPO may insist on preserving the existing materials.

**Aesthetics / owner intent.** Depending on the intended use of the building and the image the owner would like to portray, the decision to repair or replace may come down to how the building should look. A 1970s storefront might be a fine example of the period, but if the owner finds the appearance dated and unappealing, there is little point in salvaging it.

**Compatibility with surrounding architecture.** As part of a commercial district, campus, or neighborhood,

*(continued on page 8)*

# representative projects



## Storefronts

Storefronts have come a long way since they first appeared in early America. No longer limited to shop windows, storefronts can be found on many building types, from corporate headquarters to luxury apartments. With all the different systems available today, it can be daunting to find the right one. Factor in standards for energy efficiency, safety, and performance, and designing a storefront that is code-compliant and meets functional and aesthetic goals can seem overwhelming.

That's where we come in. Hoffmann Architects has over four decades of experience with storefront assemblies. We develop storefront solutions for diverse facilities, including:

### Columbia University

**528 and 560 Riverside Drive**

New York, New York

*Plaza and Storefront Renovations*

### Scholastic Headquarters

New York, New York

*Storefront and Awning Conceptual Design for Landmark Building*

### One Wall Street

New York, New York

*Building Envelope Consultation for Landmark Building, Including Storefront*

### Two Ten West 77 Residences

New York, New York

*Building Envelope Consultation for New Construction, Including Storefront Entry*

### 110 Charlton Street

New York, New York

*New Construction Consultation for Storefront System and Canopy*

### 2234 Broadway

New York, New York

*Mixed-Use Property  
Building Envelope Consultation for New Construction, Including Storefront Design*

### University of Connecticut

Storrs, Connecticut

*Central Utility Plant  
Storefront Window Replacement and Facade Repair*

### 7W21

**Flatiron Luxury Apartments**

New York, New York

*Building Envelope Consultation for New Construction, Including Storefront Entry*



**▲ 1900 K Street Office Building** in Washington, District of Columbia. *Storefront Revolving Door Assessment.*

### Starrett-Lehigh Building

**601 West 26th Street**

New York, New York

*Consultation for New Storefront and Canopy at Landmark Building*

### 221 West 77 Residences

New York, New York

*Building Envelope Consultation for New Construction, Including Storefront Entry*

### Hanover Insurance Group

**Headquarters**

Worcester, Massachusetts

*Glazing Replacement and Facade Restoration for Storefront and Windows*



**▲ M&T Bank** in Buffalo, New York. *Entrance Redesign and Plaza and Garage Rehabilitation.*



**▲ Chauncy House** in Boston, Massachusetts. *Facade Restoration, Including Storefronts.*



**▲ Figure Eight Town Center** in West Hartford, Connecticut. *Storefront Consultation.*

Hoffmann Architects, Inc.  
 2321 Whitney Avenue  
 Hamden, CT 06518

ADDRESS SERVICE REQUESTED



(continued from page 6)



▲ Not just for shops, storefronts can be used for corporate and institutional buildings, too.

storefronts are in communication with the structures that are all around them, as well as with the higher floors of the building they occupy. Creating a storefront that attracts attention but remains respectful of the surrounding built environment is a delicate balance. If the existing storefront is at odds with the rest of the area, it may be worth considering a more sensitive replacement.

**Energy performance.** With manufacturers constantly developing new and more energy-efficient products, it may be worthwhile upgrading an inefficient storefront assembly with one that is better performing. Still, replacing a serviceable storefront with a new one for

the sake of energy performance alone may not yield sufficient operating cost savings to recoup the cost of replacement. As one criteria of many, however, energy efficiency is an important consideration.

### Achieving Balanced Design

Thoughtful rejuvenation of an aging storefront demands discerning which elements are essential to the character of the building, and which should best be replaced. With energy performance now a lead driving force in storefront design, frame and glazing detailing for new storefronts must minimize thermal transfer while weighing aesthetic and functional considerations.

Whether for rehabilitation of an existing system or installation of a new assembly, storefront design is anything but simple. Options and regulations can be surprisingly nuanced, so balancing building code requirements, local jurisdiction mandates, aesthetic considerations, durability, and performance requires knowledge and experience. ■

**JOURNAL** is a publication of Hoffmann Architects, Inc., specialists in the rehabilitation of building exteriors. The firm's work focuses on existing structures, diagnosing and resolving problems within roofs, facades, windows, waterproofing materials, structural systems, plazas/terraces, parking garages, and historic and landmark structures. We also provide consulting services for new building construction, as well as litigation and claim support.

For address changes, free subscriptions, or information on the topics discussed in this issue, contact our Marketing Department at 800-239-6665, [news@hoffarch.com](mailto:news@hoffarch.com), or:

2321 Whitney Avenue  
 Hamden, CT 06518  
 203-239-6660

1040 Avenue of the Americas, Ste. 14C  
 New York, NY 10018  
 212-789-9915

2711 Jefferson Davis Highway, Ste. 333  
 Arlington, VA 22202  
 703-253-9800

[www.hoffarch.com](http://www.hoffarch.com)

Editor/Production: Alison Hoffmann



### JOURNAL offers AIA/CES Learning Units

Earn Health, Safety, and Welfare (HSW) continuing education credit for reading the JOURNAL. To learn more, visit [www.hoffarch.com](http://www.hoffarch.com).