

**Hoffmann  
Architects**

Journal of architectural  
technology published by  
Hoffmann Architects, Inc.,  
specialists in the rehabilitation  
of building exteriors.

# Journal

## Water Testing: A Tool for Owners and Design Professionals

Richard P. Kadlubowski, AIA and Courtenay Bauer

Whether performed in a laboratory or administered in the field, water testing can provide useful information on the integrity and water-tightness of building envelope systems. In some cases, water penetration testing uses a calibrated apparatus to apply water to the test sample at specific flow rates and air pressures. In other situations, water infiltration can be effectively evaluated through simple flooding or saturation of the assembly. Either way, the results of water testing allow the design professional to

evaluate performance and fine-tune recommendations.

The key to successful use of water testing is specifying controlled test methods that are appropriate to the building system and situation. With clear objectives and documentation, water testing can provide reliable data that informs decision-making and forms a basis for further action. For architects, engineers, and building owners, water testing can be an effective tool in the diagnosis of building envelope failure in existing structures, as well as in the design and evaluation of new construction.

### Common Uses for Water Testing

In the building design and construction industry, water testing serves three primary functions: product testing, new construction performance verification, and leak investigation.

#### Product Testing

Manufacturers of window and wall systems test new products for air and water infiltration and often publish performance data as part of their marketing materials. Product testing is also useful for evaluating a building system during the submittal or mock-up phases, to see that the selected product meets performance demands. When specifying a custom system, as



▲ As part of a defect survey, spray rack water tests quantify the extent and location of water penetration.

*Richard P. Kadlubowski, AIA is senior vice president with Hoffmann Architects. As manager of the firm's Washington DC office, he directs project teams in remediating water infiltration and reviewing construction designs for water-tightness. Project manager Courtenay Bauer specifies and oversees building envelope water tests for diverse applications.*



▲ High-rise buildings pose logistical challenges to water testing, including securing the test apparatus and managing overspray.



▲ Flooding a newly installed roof membrane to check for leaks is often part of the reroofing process.

opposed to a stock item, design professionals often use water testing to verify performance.

### **New Construction**

Owners interested in the long-term performance of newly installed building systems often require that such systems be tested to gain certification from the manufacturer or installer. Before issuing a warranty certificate, manufacturers may require water testing to confirm appropriately detailed, water-tight conditions at installation.

### **Leak Investigation**

Diagnostic water testing is commonly used by design professionals to determine the cause of water infiltration. Roof and wall assemblies, windows, terraces, and water features all benefit from appropriately specified and administered water tests when recurrent leaks are difficult to diagnose and resolve.

Regardless of the application, water testing must be carried out in a controlled fashion in order to yield usable data. Simulating dynamic and static pressure conditions and wind-driven rain demands a systematic approach to testing and record-keeping. Even seemingly simple water testing, such as

flooding an excavated foundation wall or saturating a masonry wall surface, requires careful monitoring to see that the test is performed in a manner that provides useful and pointed results.

### **Preparation**

Unreliable test procedures yield unreliable results. That's why it's so important to prepare, perform, observe, and document water tests according to accepted industry standards.

Before the water test is underway, the design professional must determine an appropriate sample to see that a representative portion of the system is tested. The test sample will depend on both the purpose and type of testing. For example, a flood test would aim to cover as much of a roof or plaza as possible, so as to comprehensively evaluate newly installed waterproofing for deficiencies. So too would facade water infiltration testing endeavor to achieve maximum coverage of the area under investigation. Whereas, a laboratory product test might focus on an isolated portion of the system, or perhaps only the most complex and difficult details and connections.

Depending upon the type of evaluation, testing may be conducted by the

installer; such as with a roof flood test; by a contractor assisting the architect, as during an investigation of an existing structure; or by an accredited testing laboratory. The design professional should advise the building owner as to which tests are recommended, when they should be administered, and by whom. On the day of the test, the architect or engineer should observe testing to see that water flow rates and air pressure differentials reflect those specified, and that gauges and meters, if required, are calibrated correctly.

### **Site Testing**

On-site testing may be used for both new construction and existing buildings. Before field testing takes place, the architect or engineer should define failure criteria; that is, he or she should establish conditions under which the assembly has failed to provide adequate protection against water infiltration. Depending upon the purpose of the test and the building element in question, testing may involve light-pressure mist, continuous water stream, pooling/flooding, or a combination of these.

For on-site testing, access to the test area and proper preparation of the

test sample are critical. Logistical concerns might include management of overnight testing, emergency procedures to handle leaks during testing, dams and other containment measures, and drainage of accumulated water once the test is complete. For building areas that are difficult to access, including elevated and obstructed locations, the design professional and contractor should work in consultation to determine a feasible test method.

### Flood Testing

Flood testing involves creating a dam or using a natural surround to pool water on a horizontal surface, such as a roof, terrace, or plaza, in order to identify leak locations or evaluate waterproofing integrity. For new assemblies, the test often serves as the final check to see that installation did not leave unintended holes, gaps, or openings through which water can migrate into the building. Flood testing is also a useful tool for investigation of water infiltration in existing buildings. Often, a dye or pigment is incorporated into the water to assist the design professional in tracing the pathway of the leak. Pinpointing the location and cause of water entry is essential to resolving the problem.

An alternative to flood testing is *electric field vector mapping (EFVM)*, a non-destructive test method that uses differences in electric potential to identify pinholes and other breaches in waterproofing systems. (See sidebar on page 5.)

### Laboratory Testing

Not all water tests are conducted on site. Manufacturers often use the results of laboratory water testing to market and “prove” their products. Before specification and installation of such products, however, it’s prudent to review exactly what the manufacturer claims the product will do and

how the product must be installed to achieve the stated result. Third-party product testing tends to provide more reliable results than does testing conducted by the manufacturer in-house. A testing agency’s reputation depends upon the reliability of its procedures and data reporting. Unlike the manufacturer, an independent testing lab has no stake in the product.

“Unreliable test procedures yield unreliable results.”

If project conditions differ from those used by the manufacturer during product testing, the architect or engineer may determine that additional testing is needed. Such a determination may depend on any number of factors, from owner’s performance expectations to building type and usage.

Aside from manufacturer testing, laboratory water tests may also be required by the construction specifier. Rather than stipulate a particular custom assembly or stock item, specifications may require certain performance criteria. Recorded testing data is used to demonstrate a system’s conformance with specifications. Depending upon the demands of a project, testing criteria can be as simple as a single on-site nozzle test, or as complex as a series of laboratory and field tests verifying that the product assembly

and installation are water-tight.

Laboratory testing may also be used as a means of holding manufacturers and installers accountable for quality workmanship. Testing a product in a neutral facility can establish performance independent of field conditions. An installer would be hard-pressed to blame a failure on a defective product if third-party laboratory testing previously established that product’s viability. Conversely, a laboratory test that reveals product shortcomings may lead the project team to conclude that it is a faulty product, and not faulty installation, which caused the failure.

Of course, building envelope elements do not function in isolation. Facade systems, roofs, and windows are interdependent, making it hard to draw the line between a product and its installation. No matter how rigorously a product is tested in the laboratory, neglecting to account for how it interacts with adjacent building elements can still lead to leaks and premature failure.

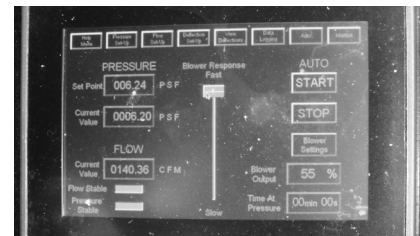

▲ Calibrated water penetration testing applies specific pressure differentials and flow rates in a controlled environment.



## Observation and Documentation

Because water tests often form the basis for major decisions concerning building envelope design or repair, results should not be taken lightly. Premature approval of a product for installation based on superficial or insufficient testing can have disastrous consequences for the longevity and water-tightness of the building envelope. For existing systems, rehabilitation strategies developed on the basis of partial or incorrect testing information may prove inadequate at best, and may even do more harm than good by failing to address the true source of water infiltration.

Although the contractor performing the testing may claim to be competent in interpreting test results, it is prudent to engage the services of an independent third-party consultant, often the architect or engineer, to document the process and outcome. That way, should disputes arise, documentation of testing results can be used to establish the veracity of reported data.

Once the test is complete, the design professional may make recommendations for corrective measures or

changes in product specifications based on the results of the test. For existing structures, the architect or engineer may use test data to determine whether the system can be repaired, or whether replacement is warranted. The test results may also be used to decide whether a product under consideration has the capability to perform under anticipated field conditions.

Should the system fail to remain water-tight, the manufacturer must modify the product to comply with specifications, or the owner and design professional may decide to select and test a new product altogether. If the test results are satisfactory, the owner and project team can then proceed with construction confident in the ability of the specified assembly to perform as expected.

## Standards and Specifications

A number of standard methods for water testing are provided by ASTM International (formerly the American Society for Testing and Materials) and by the American Architectural Manufacturers Association (AAMA), organizations that are recognized in

the design and construction industry for the development of performance standards and model specifications. Contractors or technicians conducting water testing of building systems should adhere to these or similar standards.

**Water penetration by uniform static air pressure difference** (ASTM E 331) is used to measure the water-tightness of a manufactured assembly, including windows, skylights, doors, and curtain walls. In this test method, a sealed chamber creates a controlled air pressure difference across the test specimen. Water is then sprayed at the exterior surface at a given rate for a specified period of time, then the air-pressure difference is removed and water infiltration points noted.

**Water penetration by dynamic air pressure difference** (ASTM E 2268 or AAMA 501.1) uses a wind-generating device, such as an aircraft propeller, to create the pressure differential across the test specimen. The test proceeds similarly to that of ASTM E 331, except that the dynamic wind stream is applied to the test sample, whereas a uniform static air pressure test deliberately avoids subjecting the test specimen directly to air flow. Dynamic pressure testing is intended to mimic the effects of wind-driven rain in a laboratory setting.

**Field determination of water penetration** (ASTM E 1105 or AAMA 501.2) applies similar test methods to installed windows, doors, and curtain walls of existing buildings. Air pressure at the outdoor face of the test area is higher than that at the indoor face, creating a pressure differential that tends to encourage water migration into the building. A calibrated water-spray grid is affixed to the building exterior, with spray nozzles spaced evenly. The test may be conducted using uniform static air pressure, as described above,

(continued on page 6)



▲ Off-site spray rack testing allows the design professional to verify water-tightness of the proposed assembly.



▲ High-powered fans or propellers are used to establish dynamic air pressure differences across a test sample.

## Electric Field Vector Mapping

Electric field vector mapping, or EFVM, applies an electric current to the wet surface of a roof, terrace, or plaza to identify breaches in the waterproofing system. A conductive wire loop is laid out atop the waterproofing membrane around the test area or entire roof/plaza perimeter. One lead from an electrical pulse generator is connected to this wire loop, while the other is connected to the grounded structural deck or, in the case of a wood deck, to a grounded metal screen superimposed on the deck. To identify the source of leaks, the survey technician uses a potentiometer with two probes to detect where current flows through breaches in the membrane to the grounded deck, completing the circuit.

Because EFVM relies on the electrical resistance of the roof membrane, it can be highly successful in identifying very small openings or pinholes that might not be readily visible but which nonetheless can admit enough water to saturate insulation and lead to deterioration conditions. Once breaches in the waterproofing membrane are identified, they can be repaired and then re-tested to confirm water-tightness.

Care must be taken, however, when determining the suitability of a given roof or plaza assembly for EFVM. Ethylene propylene diene terpolymer (EPDM) roof membranes, for example, act as conductors rather

than insulators, and so are not suitable candidates for EFVM testing. Some coatings or fasteners may also be incompatible with the technique.

EFVM has limited application for existing structures, as accessing the membrane and/or establishing a path to ground may be costly and difficult for some assemblies. Installing an EFVM system during initial construction can facilitate future testing, and it is relatively inexpensive to add to a project on the front end.

A major benefit of EFVM is that, unlike flood testing, it does not risk overloading a roof or plaza deck with ponded water. It can also be used on sloped roofs and other surfaces where flood testing is not possible. In addition to investigative testing, EFVM may be used to verify the integrity of new roof installations, particularly for vegetated roofs and plaza assemblies where removal of overburden to locate and repair leaks would be expensive and disruptive. EFVM also has applications for warranty verification.

Provided an electric potential may be established across the membrane assembly, vector mapping is a valuable tool not only for leak detection, but also for quality control and asset management. When used appropriately, EFVM can be a viable alternative to traditional flood testing that produces reliable, reproducible results. ■

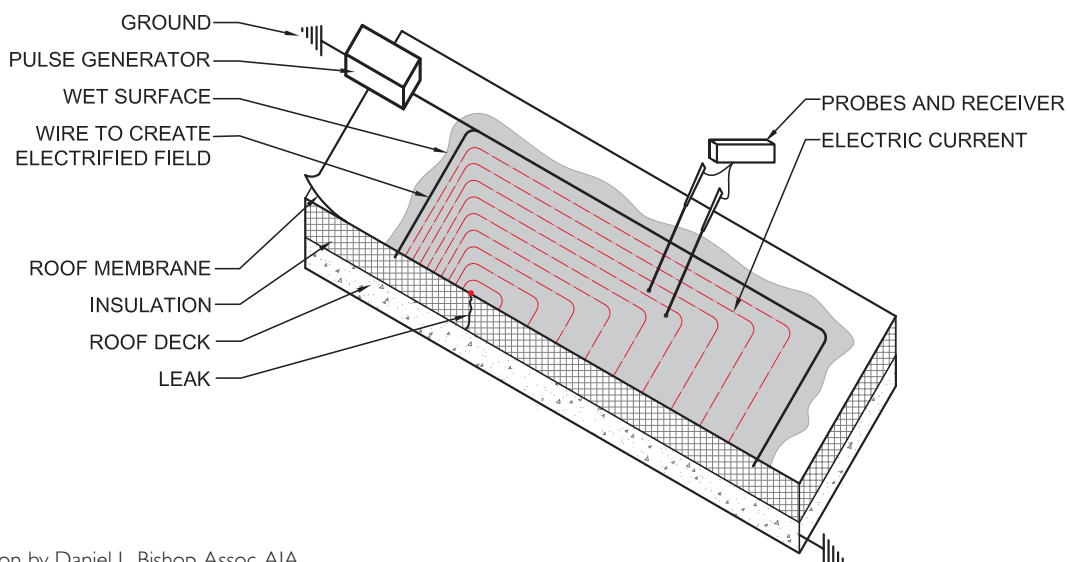
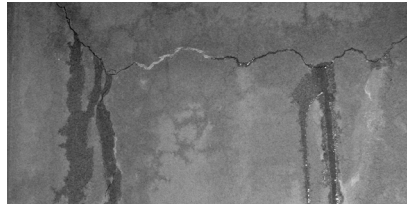
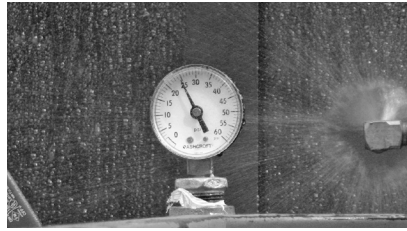

Illustration by Daniel L. Bishop, Assoc. AIA

(continued from page 4)



▲ A leak investigation in process: water is applied to the exterior envelope at the specified test pressure, whereupon the design professional documents water penetration at the interior.

or cyclic static air pressure, in which the pressure difference is periodically reduced to zero, then increased again to the specified pressure.

**Structural loading** (ASTM E 330) of the test specimen between water testing procedures may also be used to simulate potential loading conditions over the assembly's service life. Measuring the deflection, deformation, or distress of the system in response to an applied static air pressure differential not only provides useful information on the structural durability of the assembly; it also tests the system's ability to remain water-tight even when subjected to strong structural loads.

**Air infiltration** may be measured as part of laboratory testing (ASTM E 283) or in the field (ASTM E 783), concurrent with water testing. A static air pressure difference is created in a test chamber or in a sealed area of the building envelope, and a flowmeter is used to measure air flow from the exterior to the interior. For field testing, ambient weather conditions, such as barometric pressure, temperature, and relative humidity, must be taken into consideration.

These test standards are useful guidelines, but bear in mind that they are

general methodologies, not specific directives tailored to a given building or system. As such, they express a minimum testing requirement, a baseline which should be adapted by design professionals to incorporate more stringent stipulations as needed. Site, usage, and longevity performance goals should all be taken into consideration when specifying testing procedures.

In damp climates, for example, the interval of drying time between wetting periods may be brief enough that the system does not have a chance to dry out, increasing the overall demands on waterproofing assemblies. Dry climates may afford a greater tolerance for water penetration, in that moisture may evaporate before it has a chance to infiltrate the building interior or cause damage to building materials.

Other concerns for water testing include determining an appropriate air pressure differential and rate of water flow, as well as calibration standards for the test equipment. Air pressure differences across the building envelope vary considerably, and this variability must be taken into consideration when specifying the air pressure to be used during testing.

Field testing further complicates matters, as it may be difficult in practice to achieve a static air pressure differential if changes in wind pressure impact the testing apparatus. In a laboratory setting, the design professional must also consider whether the system should be tested to failure, or whether water infiltration resistance up to a specified pressure and flow rate is sufficient to achieve a satisfactory result.

Additionally, qualifying a system for installation may involve coordination of various tests, all of which must be passed prior to approval. For example, a new window system might be tested in a laboratory, as well as *in situ*, so as to document product performance and installation workmanship. Multiple forms of testing are often useful for existing systems, too. To investigate water infiltration in a masonry wall assembly, for instance, the design professional may specify water testing with a spray rack, in conjunction with moisture readings at the building interior and invasive probes at suspect locations. The various test procedures complement and build on one another, providing a holistic picture of conditions and performance.

### Successful Application of Water Testing

With the guidance of a knowledgeable design professional and the work of an experienced contractor or technician, water testing can be hassle-free and highly beneficial. For new construction or rehabilitation, it is important to determine that the product meets the performance requirements and field conditions for the specified application. Otherwise, the system may fail prematurely, incurring expenses—from repair of damaged building elements to loss of business and inventory—that far exceed the modest cost of water testing.

For existing buildings, water testing is a

(continued on page 8)



# representative projects



## Water Testing

As part of a failure investigation or new construction peer review, Hoffmann Architects frequently specifies, oversees, and interprets the results of water penetration testing. Both on site and at testing facilities, our architects and engineers develop water test strategies that guide waterproofing design and assist in pinpointing weaknesses in building systems.

From roof and plaza flood testing to spray-rack tests of facade elements, Hoffmann Architects has incorporated water testing into a variety of projects, including:

### Seneca Allegany Casino & Hotel

Salamanca, New York  
*Curtain Wall Installation Testing and Review*



▲ **Arts and Industries Building** at the Smithsonian Institution in Washington, District of Columbia. *On-Site and Off-Site Window Assembly Water Testing.*

### New Boston Fund, Inc.

30 Trefoil Drive  
Trumbull, Connecticut  
*Curtain Wall Water Testing*

### Lawrence Apartments

Princeton University  
Princeton, New Jersey  
*Window Assembly Water Testing*

### Ellington Apartments

Washington, District of Columbia  
*Roof Flood Testing*

### Gillette Castle

East Haddam, Connecticut  
*Facade and Roof Water Testing*

### MedImmune Manufacturing Center

Frederick, Maryland  
*Wall Panel Testing*

### ARINC International Headquarters

Annapolis, Maryland  
*Foundation Water Testing*



▲ **The Sheffield** in New York, New York.  
*Window and Facade Water Testing.*

### Earth and Space Sciences Building

Stony Brook University  
Stony Brook, New York  
*Window Assembly Water Testing*

### John K. Mullen of Denver Library

The Catholic University of America  
Washington, District of Columbia  
*Window and Facade Water Testing*

### The Washington Court Hotel

Washington, District of Columbia  
*Roof Flood Testing*

### Citibank, Elmhurst Financial Center

Elmhurst, New York  
*Plaza Flood Testing*

### Albion Correctional Facility

Albion, New York  
*Facade Water Testing*

### Folger Shakespeare Library

Washington, District of Columbia  
*Book Vault Flood Testing*

Hoffmann Architects, Inc.  
2321 Whitney Avenue  
Hamden, CT 06518

ADDRESS SERVICE REQUESTED



(continued from page 7)

reliable way to determine the location and cause of leaks, and to evaluate the performance of aging windows, doors, and curtain walls as part of the repair/replace decision-making process. Pinpointing the source of water entry is cost-effective in that it enables building owners and facility managers to direct repair dollars to those areas where they are needed most. Otherwise, time and money are too often wasted on repeat repairs that fail to resolve the problem.

Coupled with other investigation techniques, including visual inspection, exploratory openings, moisture readings, vector mapping, and infrared thermography, water testing can identify weak points and failure in building envelope systems. When used at appropriate stages during the investigation, design, and construction process, water testing can prove invaluable to the prevention and mitigation of water infiltration. ■

**JOURNAL** is a publication of Hoffmann Architects, Inc., specialists in the rehabilitation of building exteriors. The firm's work focuses on existing structures, diagnosing and resolving problems within roofs, facades, windows, waterproofing materials, structural systems, plazas/terraces, parking garages, and historic and landmark structures. We also provide consulting services for new building construction, as well as litigation and claim support.

For address changes, free subscriptions, or information on the topics discussed in this issue, contact our Marketing Department at 800-239-6665, [news@hoffarch.com](mailto:news@hoffarch.com), or:

2321 Whitney Avenue  
Hamden, CT 06518  
203-239-6660

1040 Avenue of the Americas, Ste. 14C  
New York, NY 10018  
212-789-9915

2611 Jefferson Davis Highway, Ste. 200  
Arlington, VA 22202  
703-253-9800

[www.hoffarch.com](http://www.hoffarch.com)

Editor: Alison Hoffmann  
Production: Cari Tate



**JOURNAL** offers AIA/CES Learning Units

Earn Health, Safety, and Welfare (HSW) continuing education credit for reading the JOURNAL.

To learn more, visit [www.hoffarch.com](http://www.hoffarch.com).